

BARNEGAT BAY YACHT RACING ASSOCIATION

REGATTA COMMITTEE MEETING II

February 25, 2006 at 1000

Toms River Yacht Club

MINUTES

The meeting was called to order by Commodore William E. Scheyer at 1000. Bill welcomed those present and thanked the Toms River Yacht Club for hosting our meeting.

Roll call, by Secretary Betty Jane France, indicated that all clubs were represented with the exception of NBYC.

Minutes of the 11/19/05 Regatta I Meeting were approved as mailed.

There was no correspondence.

OFFICER REPORTS:

REGATTA

Vice Commodore Robert T. Morrow, as Chairman of the Regatta Committee, presided over the remainder of the meeting.

Bob reported that the Notice of Race and Schedule are ready for final approval.

He thanked Sailing Instructions Chairman Jim Carson and his committee members Roger Brown, Peter Chance, Len Egee, Rich Kerdock, Del Kusma, and Dave Magno for their hard work since the 11/19/05 Liaison Committee Meeting developing schedules and making changes to accommodate the addition of the 420 Class, including a proposed addendum for the Club 420 Class Sailed in Collegiate Mode.

420s will be a provisional class, with no age restrictions, sailing in a second racing circle under the leadership of the BBYRA Regatta Committee.

The Laser Radial Adult Women Class will continue as a provisional class.

Nominations for BBYRA Special Awards (Dale, Powell, and LaPier) will be accepted the morning of the LYC Regatta; a meeting of the Regatta Committee, to select recipients, will be held after the Start Boat docks the same day.

A Regatta Committee practice session will be held prior to the start of the racing season.

Those needing name tags should see Bob France.

CLASS LIAISON

Rear Commodore Richard P. Proko reported that the classes provided suggestions and recommendations at the 11/19/05 Liaison Meeting; it has been quiet since.

The BBYRA web site will be used for crew match-ups next summer.

EQUIPMENT

Rear Commodore Proko will be purchasing three voice recorders and a 420 flag, along with sundry

other equipment.

Roy Wilkins offered use of marks for the 420 course.

SAFETY

Fleet Captain Edwin Reardon will schedule defibrillator training in June.

TRAINING

Fleet Captain Reardon thanked Jim Walsh and Chris Petracco for assuming responsibility for the USSailing Judges Training held at MRYC on 2/10/06 & 2/11/06.

MEASURER

Measurer James G. Carson has recommended that the Sanderlings reassess their upper wind limit and seriously consider the use of reefs to allow sailing in winds we normally encounter on Barnegat Bay on summer afternoons (18-22 knots) thus reducing the number of abandonments. That recommendation is apparently still under consideration by the fleet but could be implemented at the last minute.

There are three types of 420s: The International 420, the Club 420, and the collegiate C420. Since the boats used in BBYRA club programs are Club 420s, Club 420 sailed in collegiate mode (spinnaker and trapeze not used) allows use of all 420s generally available in the area without modification.

SAILING INSTRUCTIONS

Chairman James G. Carson explained the Proposed 2006 Sailing Instruction changes.

The Sailing Instructions Committee addressed inclusion of 420s into the program by:

1. Formulating a Proposed Addendum to the BBYRA Sailing Instructions for Club 420 Class Sailed in Collegiate Mode (no spinnaker and no trapeze).
2. 420s will have their own sailing area in proximity to the BBYRA sailing area.
3. Their start/finish line will be approximately in the middle of the course with finishes to windward.

Relative to portable mark courses:

1. All other classes will always first sail to an initial mark located to windward of the starting area (no green flag); boats must leave this mark to port prior to assuming the posted course.
2. The windward mark will be moved further to weather.
3. To provide for dual-length windward/leeward legs, two leeward marks will be used.
4. The upwind finish line will be to weather of the windward mark.

Boats will start in speed order, fastest first.

COMMITTEE REPORTS:

APPEALS

Chairman Chris Petracco had no appeals to report.

Dave Perry attended the recent Judges Seminar where attendees learned that most appeals getting to USSailing level are due to protest committee procedure.

Three Judges Seminars will be given every 18 months throughout Area C, one of which will be within the BBYRA area.

SCORING

Assistant Scorer John D. Heacock and Registrar/Assistant Scorer Eileen King reported that the computer and Scorer Harold Lewry will be ashore. Harold needs all data, including inspection information ASAP.

US SAILING NATIONAL CUP EVENTS

Chairman James Walsh reported the following:

Sears, Bemis, and Smythe:

1. BBYRA Eliminations will be held on 7/11/06 at NBYC.
2. Area C Eliminations will be held on 7/19/06, Sears at LYC, Bemis and Smythe at MYC/BHYC.

Area A, B, C Prince of Wales Sailoffs will be on 6/24/06 & 6/25/06; applications must be submitted for the 18 available spots.

Bill Bogardus is still involved with Adams and Mallory events.

Lauren Plump announced that the Independence Cup will be held 6/10/06 at TRYC.

US SAILING

YRA Representative Harry K. Foote, sent the following report:

1. He plans to attend the USSailing meeting which will be held 3/17/06 through 3/19/06 in Chicago.
2. The revised By-Laws for the Board and House of Delegates are in draft form and are expected to be approved.
3. Area C had an organizational meeting and the schedule is well on its way to completion.
4. Through the generous help of Jack Heacock, an Area C site has been started.

Recent legislation requires the following:

1. Persons born in 1969 or later must possess a Boating Safety Certificate by 6/1/06.
2. Persons born in 1959 or later must possess a Boating Safety Certificate by 6/1/07.
3. Persons born in 1949 or later must possess a Boating Safety Certificate by 6/1/08.
4. All who wish to operate a power vessel must possess a Boating Safety Certificate by 6/1/09.

OLD BUSINESS:

2006 BBYRA COMMODORES' BALL

The ball will be held on 6/3/06 at MCYC with cocktails from 1830 to 1930 and the sit-down catered dinner at 1930. The cost is \$65.

2006 BBYRA YEARBOOK

Cochairman James G. Carson reported the following:

1. Historian Don Bottomley will update the history.
2. BBYRA member clubs' addresses and phone numbers will be included this year.
3. Club Commodores will be asked for Host Club Trophies and Open Regattas information.
4. Ads are coming in.
5. 4/1/06 is the absolute deadline for information and ads.

2006 WEB PAGE

Webmaster John D. Heacock, reported the following:

1. The web page has 800 pages, most in the archives.
2. There will be coordination with the yearbook.
3. Jack welcomes results of open regattas and will post them.

NEW BUSINESS:

2006 PROPOSED REGISTRATION PROCEDURES

The Season Registration Fee schedule was distributed.

1. Procedures are similar to last year with the Season Registration form on the BBYRA web site, <http://www.bbyra.org>.
2. Lunches are again optional, but must be ordered by 6/15/06.
3. One set of Tyvek course sheets (one up-bay and one down-bay) will be included with Season Registration. Extras will cost \$4 per set.

Rear Commodore Proko will get word out to the Fleet Captains that BBYRA is open for business.

If registering on a daily basis, the cost is \$10 per race for all classes except 420s, where cost is \$5 per race.

2006 PROPOSED NOTICE OF RACE

Vice Commodore Morrow discussed the Proposed 2006 Notice of Race:

1. 420 Class has been added.
2. Season Registration is by mail until 6/15/06 and at Regatta Headquarters until 34% of those races scheduled for a boat's class have been sailed.
3. The first warning signal in the morning is at 0920; in the afternoon at 1330.
4. Classes will start in speed order.
5. Instead of Lasers sailing two AM races on 7/15/06 at TRYC, they will sail two on 7/8/06 at MYC/MRYC.

A motion was made, seconded, and passed to approve the Proposed 2006 Notice of Race.

2006 PROPOSED RACING RULES

A motion was made, seconded, and passed approving changes to the Racing Rules before submittal to the Executive Committee for review and approval and then submittal to the Delegates for final action.

2006 PROPOSED SAILING INSTRUCTIONS

A motion was made, seconded, and passed giving the Sailing Instructions Committee permission to make wording, not intent, changes.

The Sailing Instructions Committee will add a description of initial mark and look at "wear personal buoyancy at all times while afloat".

A motion was made, seconded, and passed accepting the Proposed Sailing Instructions subject to proposed changes brought up today.

The meeting was adjourned at 1140.

Respectfully submitted,



Betty Jane France, Secretary

Betty Jane

BBYRA
MEASURERS REPORT
REGATTA COMMITTEE MEETING, February 25, 2006

The BBYRA Measurer is charged with maintaining a copy of each class's current scantlings. Records are up-dated each spring after solicitation of all active Classes for up-dated information. This will again be done in June.

Attached is the current status of Class Documents on File.

At our last meeting I recommend the Sanderlings reassess their upper wind limit and seriously consider the use of reefs to allow sailing in winds we normally encountered on Barnegat Bay on summer afternoons (18-22 knots) thus reducing the number of abandonments. I believe that recommendation is still under consideration and of course could be implemented at the last minute.

With respect to 420's, at the November meeting I was asked to "address weight and other typical measurement issues." Via the websites and in communication with Vanguard, I confirmed that there are three types of 420's. The International 420, the Club 420 and the collegiate C420. The Club 420 rigging and hull is identical to a non-spinnaker C420 with the exception of the spinnaker and trapeze gear. Some colleges have taken the basic C420 and modified it with a slant towards more durability that generally adds weight to the overall boat. Since the boats used in BBYRA Club programs are Club 420's it was my recommendation that we describe the boat to be used on the Bay as "Club 420 sailed in collegiate mode (spinnaker and trapeze not used). This allows use of ALL 420's generally available in the area without modification. The Class Rules of the Club 420 Association will apply.

Respectfully submitted,



James G. Carson

CLASS DOCUMENTS ON FILE

Active Classes

A-Cat	6/08/02
Club 420	1/14/06
E-Sloop	2000
Ensign	2001 (indicated current 11/22/03)
Flying Scot	6/13/03
Laser	8/17/04
Laser Radial	8/17/04
Lightning	8/05
M-Sloop	1997 (indicated current 07/12/04)
Sanderling	6/30/04
Sneak Box	1993 (indicated current 11/30/02)
Sandpiper	5/2000
Sunfish	2004-2005

Inactive Classes

Blue Jay	2002
Hobie '18'	7/88
Laser II	5/91
Penguin	3/20/78
Prindle "18"	6/83

JGC
02/23/06

BBYRA
PROPOSED 2006 SAILING INSTRUCTION CHANGES
(Additions in ***bold italics***; deletions ~~crossed out~~.)

Changes to accommodate addition of 420's:

1.2 ADDENDUM TO THE BBYRA SAILING INSTRUCTIONS FOR CLUB 420 CLASS SAILED IN COLLEGIATE MODE will apply to the Club 420 Class and when in conflict supercedes these BBYRA Sailing Instructions except at the Seaside Park Regatta.

15.1 All **Club 420** ~~Junior class competitors (Laser Radial)~~ and single-handed competitors shall wear personal buoyancy at all times while afloat. This changes RRS 40 and the Part 4 preamble.

Change to relocate Portable Course windward finish:

26. THE FINISH

The finishing line will be between a staff displaying an orange flag on a Finish Boat displaying the flag/flags designating the class/classes using this finish line and ~~the nearby mark~~ **an orange ball to weather of the windward mark** except Courses 7 and 8 that will finish between a Finish Boat and an orange ball in the vicinity of the leeward mark.

Changes to always make Schmoo the initial mark on Portable Courses:

~~7.4 Green Shape/Flag: When displayed at a class's Preparatory Signal means a special green initial mark will be placed approximately 100-200 yards to starboard of the first PORTABLE mark. Round or pass this mark to port prior to assuming the posted course. This changes RRS 27.1.~~

USE OF AN "INITIAL MARK"

In order to separate the Fleets, the BBYRA is ~~initiating the use of~~ **using** an INITIAL MARK (**IM**) located to windward of the starting area. ~~When, and only when, a green shape or flag is displayed with the course designation,~~ Boats must leave this mark to port prior to assuming the posted course. The initial mark will be placed approximately 100-200 yards to the right of the first portable mark.

Changes to provide for dual length windward/leeward legs on Portable Courses:

23.3 A short leeward mark may be used and will be signaled by placard "S" following the course number.

24. MARKS

Marks will be yellow inflatables. New marks, as provided in instruction 25, Change of Course after the Start, will be orange inflatables. **A short leeward mark will be yellow with a black band.**

Note: Portable Mark Course Illustrations will be adjusted to reflect above changes.

Adjustment of starting order:

FIRST MORNING RACE WARNING 9:20AM

<u>Class</u>	<u>Signal</u>
E Sloop	E
M Sloop	T
Laser	R
Laser Radial	K
Sunfish	W
Sneakbox	G
Sandpiper	O
Club 420	Class Flag

FIRST AFTERNOON RACE WARNING 1:20PM

<u>Class</u>	<u>Signal</u>
E Sloop	E
A Cat	U
Lightning	F
Flying Scot	V
Ensign	D
Sunfish	W
Sanderling	J

Other changes:

~~7.5~~ **7.4** No later than the warning signal, the race committee signal boat may display the approximate compass bearing of the first leg.

~~7.6~~ **7.5** Any special course will be posted on the Official Notice Board at least two hours prior to the scheduled Warning Signal.

8.2 Temporary marks will be as noted in paragraphs ~~7.4~~, 9.3, 11.2, 18, ~~23.3~~, 24, 26, and AA on the Course Chart.

9.4 An orange ball attached to a Signal or Finish Boat is considered a part of the ~~mark~~ **boat**.

PROPOSED CHANGES TO RACING RULES OF THE BBYRA

APPENDIX 1
SAFETY EQUIPMENT REQUIREMENT CHECK LIST

	Paddle	Pump or Bailer ¹	Anchor	Anchor/ Tow Line ²	Life Vest ³	Throwable ³
"A" Cat	No	Yes	Yes	Yes	Yes	Yes
Club 420	Yes	Yes	No	Yes	Yes	No
Ensign	No	Yes	Yes	Yes	Yes	Yes
"E" Sloop	Yes	Yes	Yes	Yes	Yes	Yes
Flying Scot	Yes	Yes	Yes	Yes	Yes	Yes
Laser	No	No	No	Yes	Yes	No
Lightning	Yes	Yes	Yes	Yes	Yes	Yes
"M" Sloop	Yes	Yes	Yes	Yes	Yes	No
Sanderling	No	Yes	Yes	Yes	Yes	Yes
Sandpiper	Yes	Yes	Yes	Yes	Yes	No
Sneakbox	Yes	Yes	Yes	Yes	Yes	No
Sunfish	No	No	No	Yes	Yes	No

- Notes:**
1. Manual bailer Min 4 quart.
 2. All boats must carry a topline solely dedicated to towing and/or anchoring and readily available for use at all times. Line must be at least 24' long and of sufficient strength to tow a swamped boat.
 3. All boats must carry a whistle attached to throwable or life vest.

**Proposed ADDENDUM TO THE BBYRA SAILING INSTRUCTIONS
FOR CLUB 420 CLASS SAILED IN COLLEGIATE MODE**

Note: This addendum (except RULE 1.3) does not apply at the Seaside Park Regatta on 9/2. Use the BBYRA Sailing Instructions, Seaside Park, 2006

1. RULES

- 1.1 Barnegat Bay Yacht Racing Association Sailing Instructions for 2006 apply except as modified by this Addendum.
- 1.2 RRS Appendix Q, Sound Signal Starting System will apply and when in conflict supercedes the Barnegat Bay Yacht Racing Association Sailing Instructions.
- 1.3 The Club 420 will be sailed in Collegiate Mode (no spinnaker and no trapeze).

2. SCHEDULE

- 2.1 On scheduled race days the first warning signal will be at 10 AM. Subsequent races will be started as soon as possible after the end of the previous race.
- 2.2 Three races are scheduled on each race day.

3. THE COURSE

- 3.1 The 420 Class will have its own sailing area in proximity to the BBYRA sailing area. The Start/Finish Boat for the 420 Class will at all times prominently display the 420 Class Flag.
- 3.2 The course(s) will be a Triangle, Olympic or Windward-Leeward, with all marks left to port.
- 3.3 The Start/Finish line will be approximately in the middle of the course, and finishes will be to windward. Courses may be described orally, by placard or by chalkboard.

4. MARKS

- 4.1 Marks of the course and the start/finish mark will be red or orange bubbles.

5. THE START/FINISH

- 5.1 The Start/Finish line will be between a staff displaying an orange flag on the Start/Finish boat at the starboard end and a red or orange bubble at the port end.

6. CHANGE OF COURSE AFTER THE START

- 6.1 A change of course may be given orally.
- 6.2 When there is a course change marks may be relocated rather than replaced prior to the first boat rounding the preceding mark.

02/23/06

BBYRA WEEK TO WEEK SCHEDULE, 2006

BH/MC	IHYC	MA/MR	TRYC	SAYC
MORNING RACES				
FIRST WARNING				
9:20 AM	9:20 AM	9:20 AM	9:20 AM	9:20 AM
E SLOOP	E SLOOP	E SLOOP	E SLOOP	E SLOOP
M SLOOP	M SLOOP	M SLOOP	M SLOOP	M SLOOP
LASER	LASER	RADIAL	LASER	LASER
RADIAL	RADIAL	SNEAK	RADIAL	RADIAL
SUNFISH	SUNFISH	SANDPIP	SNEAK	SUNFISH
SNEAK	SNEAK	A CAT **	SANDPIP	SNEAK
SANDPIP	A CAT **		CLUB 420 ***	SANDPIP
	CLUB 420 ***			
SECOND WARNING				
E SLOOP	E SLOOP	E SLOOP	E SLOOP	E SLOOP
M SLOOP	M SLOOP	M SLOOP	M SLOOP	M SLOOP
SUNFISH	SUNFISH	SANDPIP	LASER	SANDPIP
SANDPIP			SANDPIP	
** A CAT NOT SCORED MORNING RACES				
*** CLUB 420 SAILS MULTIPLE RACES ON SEPARATE COURSE				
AFTERNOON RACES				
FIRST WARNING				
1:20 PM	1:20 PM	1:20 PM	1:20 PM	1:20 PM
E SLOOP	E SLOOP	E SLOOP	E SLOOP	E SLOOP
A CAT	A CAT	A CAT	A CAT	A CAT
LIGHT	SCOT	LIGHT	ENSIGN	LIGHT
SCOT	ENSIGN	SANDER	SANDER	SCOT
SUNFISH	SUNFISH			ENSIGN
SANDER	SANDER			SUNFISH
				SANDER
SECOND WARNING				
E SLOOP	E SLOOP	E SLOOP	E SLOOP	E SLOOP
A CAT	A CAT	A CAT	ENSIGN	A CAT
SUNFISH	SCOT	LIGHT		LIGHT
	ENSIGN	SANDER		ENSIGN
	SUNFISH			

PROPOSED

BBYRA WEEK TO WEEK SCHEDULE, 2006

OG/PB	NBYC	BYC	LYC	SPYC	
MORNING RACES					
FIRST WARNING					# RACES
9:20 AM	9:20 AM	9:20 AM	9:20 AM	9:20 AM	
M SLOOP	LASER	E SLOOP	E SLOOP	E SLOOP	15
LASER	RADIAL	RADIAL	M SLOOP	M SLOOP	15
RADIAL	SUNFISH	SUNFISH	LASER	LASER	10
SNEAK	SNEAK	SNEAK	RADIAL	RADIAL	10
CLUB 420 ***	SANDPIP	CLUB 420 ***	SNEAK	SUNFISH	10
	CLUB 420 ***		SANDPIP	SNEAK	10
				SANDPIP	13
				CLUB 420	16
SECOND WARNING					
M SLOOP	LASER	E SLOOP	E SLOOP		
	SUNFISH	SUNFISH	M SLOOP		
	SANDPIP		SANDPIP		
AFTERNOON RACES					
FIRST WARNING					
1:20 PM	1:20 PM	1:20 PM	1:20 PM	1:20 PM	
A CAT *	SCOT	E SLOOP	E SLOOP	E SLOOP	15
LIGHT	SUNFISH	A CAT	A CAT	A CAT	15
SCOT	SANDER	SCOT	LIGHT	LIGHT	10
ENSIGN		SUNFISH	SCOT	SCOT	10
SANDER			ENSIGN	ENSIGN	10
			SANDER	SUNFISH	10
				SANDER	12
SECOND WARNING					
LIGHT	SCOT	E SLOOP	E SLOOP		
ENSIGN	SUNFISH	A CAT	A CAT		
	SANDER	SUNFISH	LIGHT		
			SANDER		
* A CAT START FROM ANCHOR FINISHES AT FORKED RIVER					

PROPOSED

PROPOSED 2006 SAILING SCHEDULE

(# in parentheses) indicates number of scheduled races

JUNE 24 - (at Mantoloking Yacht Club)	Bay Head Yacht Club Metedeconk River Yacht Club
--	--

Morning: E SLOOP (2), Laser, Laser Radial, M SLOOP (2), Sandpiper (2), Sneakbox, Sunfish (2)

Afternoon: A CAT (2), E SLOOP (2), Flying Scot, Lightning, Sanderling, Sunfish (2)

JULY 1	Island Heights Yacht Club
---------------	----------------------------------

Morning: A CAT (Special Race), Club 420 (3), E SLOOP (2), Laser, Laser Radial, M SLOOP (2), Sneakbox, Sunfish (2)

Afternoon: A CAT (2), E SLOOP (2), Ensign (2), Flying Scot (2), Sanderling, Sunfish (2)

JULY 8 - (at Mantoloking Yacht Club)	Manasquan River Yacht Club Mantoloking Yacht Club
---	--

Morning: A CAT (Special Race), E SLOOP (2), Laser Radial, M SLOOP (2), Sandpiper (2), Sneakbox

Afternoon: A CAT (2), E SLOOP (2), Lightning (2), Sanderling (2)

JULY 15	Toms River Yacht Club
----------------	------------------------------

Morning: Club 420 (3), E SLOOP (2), Laser (2), Laser Radial, M SLOOP (2), Sandpiper (2), Sneakbox

Afternoon: A CAT, E SLOOP (2), Ensign (2), Sanderling

JULY 22	Shore Acres Yacht Club
----------------	-------------------------------

Morning: E SLOOP (2), Laser, Laser Radial, M SLOOP (2), Sandpiper (2), Sneakbox, Sunfish

Afternoon: A CAT (2), E SLOOP (2), Ensign (2), Flying Scot, Lightning (2), Sanderling, Sunfish

JULY 29	Open Weekend - No B.B.Y.R.A. Races
----------------	---

AUGUST 5 - (at Ocean Gate Yacht Club)	Ocean Gate Yacht Club Pine Beach Yacht Club
--	--

Morning: Club 420 (3), Laser, Laser Radial, M SLOOP (2), Sneakbox

Afternoon: Ensign (2), Flying Scot, Lightning (2), Sanderling

Special: A CAT start from anchor

AUGUST 12	Normandy Beach Yacht Club
------------------	----------------------------------

Morning: Club 420 (3), Laser (2), Laser Radial, Sandpiper (2), Sneakbox, Sunfish (2)

Afternoon: Flying Scot (2), Sanderling (2), Sunfish (2)

AUGUST 19	Beachwood Yacht Club
------------------	-----------------------------

Morning: Club 420 (3), E SLOOP (2), Laser Radial, Sneakbox, Sunfish (2)

Afternoon: A CAT (2), E SLOOP (2), Flying Scot, Sunfish, (2)

AUGUST 26	Lavallette Yacht Club
------------------	------------------------------

Morning: E SLOOP (2), Laser, Laser Radial, M SLOOP (2), Sandpiper (2), Sneakbox

Afternoon: A CAT (2), E SLOOP (2), Ensign, Flying Scot, Lightning (2), Sanderling (2),

SEPTEMBER 2	Seaside Park Yacht Club
--------------------	--------------------------------

Morning: Club 420, E SLOOP, Laser, Laser Radial, M SLOOP, Sandpiper, Sneakbox, Sunfish

Afternoon: A CAT, E SLOOP, Ensign, Flying Scot, Lightning, Sanderling, Sunfish

2/22/06

PROPOSED

2006 BBYRA Season Championship Fee Schedule

Class	Pre-Season Registration Fee (on or before 6/15/06)	Seasonal Registration Fee (after 6/15/06)
E Sloop (AM or PM Only)	\$95.00	\$120.00
E Sloop (Both)	\$190.00	\$215.00
M Sloop	\$60.00	\$85.00
Laser	\$55.00	\$80.00
Laser Radial	\$55.00	\$80.00
Laser Radial Adult Women	\$55.00	\$80.00
Sunfish (AM or PM Only)	\$55.00	\$80.00
Sunfish (Both)	\$110.00	\$135.00
Sneakbox	\$60.00	\$85.00
Sandpiper	\$60.00	\$85.00
Collegiate 420*	\$60.00	\$85.00
Sanderling	\$70.00	\$95.00
A-Cat*	\$100.00	\$125.00
Lightning	\$70.00	\$95.00
Flying Scot	\$70.00	\$95.00
Ensign	\$70.00	\$95.00

***Notes:** A Cat may register for the two morning special non-scored races by adding \$20.00 (two Daily entries) to their registration.

Collegiate 420 is a Club 420 sailed in collegiate mode (non spinnaker without trapeze).

From: "Harry Foote" <harry.foote@raymondjames.com>
 Subject: Saturday's meeting
 Date: February 22, 2006 3:46:40 PM EST
 To: "Betty Jane France" <bfrance@rcn.com>
 1 Attachment, 42.8 KB

Hi, unfortunately I will not be able to attend Saturday's meeting at TRYC. Please pass the following information on for me:

US Sailing meeting will be held March 17th through the 19th in Chicago and I plan on attending. The revised By-Laws for the Board and House of delegates are in draft form and I expect them to be approved. On a local note, Area C had an organizational meeting and the schedule is well on its way for completion. Through the generous help of Jack Heacock we have started an Area C site where everyone in the "Area" can see upcoming events and attend if interested. More needs to be done in the coordinating with other RSA's but we plan on having it operational in the near future.

As an aside I did receive an email for Sue concerning Boating Safety Certificates...could be a problem for Sailing Instructors. I have attached what she had sent and if she is correct we need to address this.

Thanks hope you have a successful meeting and I look forward to seeing you soon.
 H

**BOATING SAFETY EDUCATION
 & MINIMUM AGE MANDATORY REQUIREMENTS**

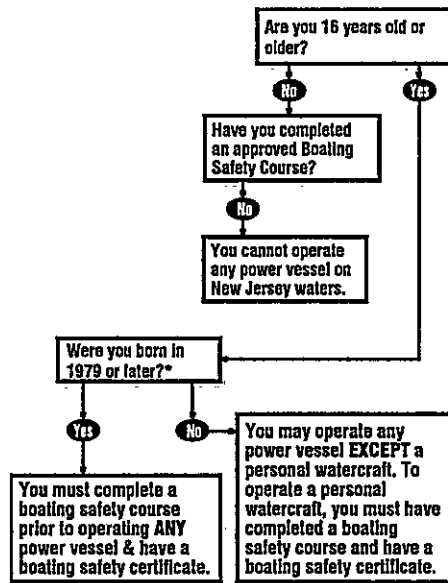

***Schedule for Completion of Mandatory Boating Safety Course:**

- Persons born in 1969 or later must possess a Boating Safety Certificate by June 1, 2006.
- Persons born in 1959 or later must possess a Boating Safety Certificate by June 1, 2007.
- Persons born in 1949 or later must possess a Boating Safety Certificate by June 1, 2008.
- All persons who wish to operate a power vessel must possess a Boating Safety Certificate by June 1, 2009.

**BOATING SAFETY EDUCATION
 & MINIMUM AGE MANDATORY REQUIREMENTS
 For Those Under 16**

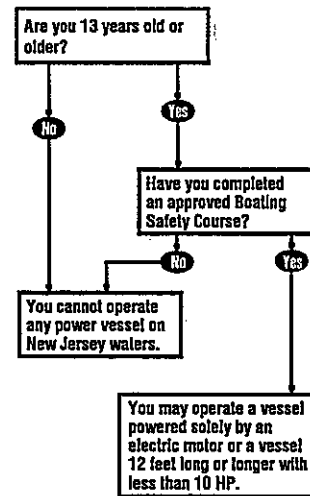

- 1) There are NO EXEMPTIONS to New Jersey age requirements.
- 2) Out-of-state residents in New Jersey for less than 90 days with a certificate issued by their state or country; OR written proof of completion of a substantially similar course to the NJ-approved course will satisfy the education requirements.

Boating Safety Course information may be located at:
www.cgaux.org • www.usps.org • www.BOATUS.com
 Boating Safety Courses must be completed in person.

BOATING SAFETY EDUCATION & MINIMUM AGE MANDATORY REQUIREMENTS

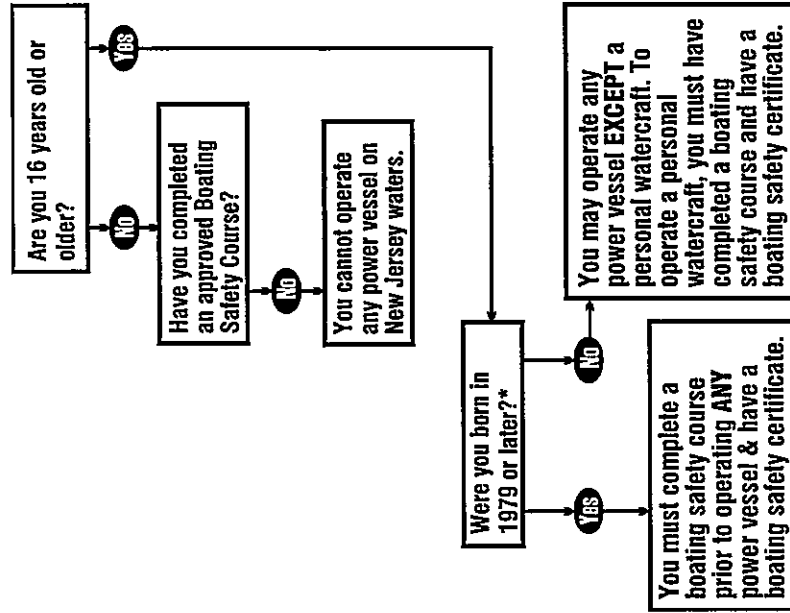

***Schedule for Completion of Mandatory Boating Safety Course:**

- Persons born in 1969 or later must possess a Boating Safety Certificate by **June 1, 2006.**
- Persons born in 1959 or later must possess a Boating Safety Certificate by **June 1, 2007.**
- Persons born in 1949 or later must possess a Boating Safety Certificate by **June 1, 2008.**
- All persons who wish to operate a power vessel must possess a Boating Safety Certificate by **June 1, 2009.**

BOATING SAFETY EDUCATION & MINIMUM AGE MANDATORY REQUIREMENTS *For Those Under 16*

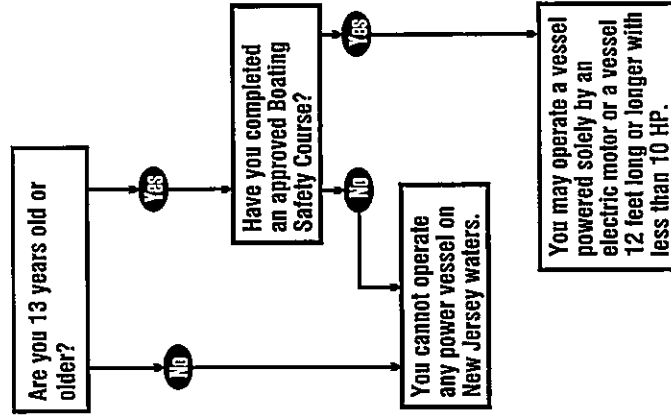

- 1) There are **NO EXEMPTIONS** to New Jersey age requirements.
- 2) Out-of-state residents in New Jersey for less than 90 days with a certificate issued by their state or country; **OR** written proof of completion of a substantially similar course to the NJ-approved course will satisfy the education requirements.

Boating Safety Course information may be located at:
www.cgaux.org • www.usps.org • www.BOATUS.com
 Boating Safety Courses must be completed in person.

New Jersey Law Sets Short Deadline

In early January, New Jersey became the latest state to join the ranks of those that require boat operators to take an accredited safety class or pass a test. A bill passed in the final days of the New Jersey legislative session took effect immediately, raising concerns over the extremely short time frame for compliance. How the state is going to certify the owners of 209,000 registered boats practically overnight is unclear.

A potential stumbling block is that volunteer boating instructors mainly offer their classes in the winter months. Anyone born after Dec. 31, 1978 is required to immediately take an approved boating safety course, even though the state has barely had time to determine which courses are approved. The new law applies to anyone 16 and older who operates a motorized vessel larger than 12 feet.

Those born after Dec. 31, 1968 must take the course before June 1 of this year; those born after Dec. 31, 1958 must comply by June 1, 2007; those born after Dec. 31, 1948 must comply by June 1, 2008. All boat operators must comply by June 1, 2009. The law also updates requirements for the use of personal watercraft. Anyone 16 and older who operates a PWC must

take a safety course.

While BoatU.S. members support mandatory education (see related story, page 22), BoatU.S. expressed concern to the bill's sponsor, Assemblyman Robert J. Smith, that the bill also required criminal background checks of all instructors — who are largely U.S. Coast Guard Auxiliaries and U.S. Power Squadrons members — at their own expense. This makes little sense as they are mainly teaching adult students and such a burden on volunteers may shrink the number of available instructors when they are needed most.

The bill as passed also allows an "experienced" boater to take an equivalency test instead of a course but the level of experience is not defined. In addition, out-of-state boaters are not necessarily exempt from the law as the final version "exempts" them only if they have an equivalent education certificate from their home state. Many boaters who visit or pass through New Jersey come from states where they have no such requirement. The vast majority of state education laws exempt out-of-state boaters. How the state boating office will handle these enforcement issues is still up in the air at presstime.

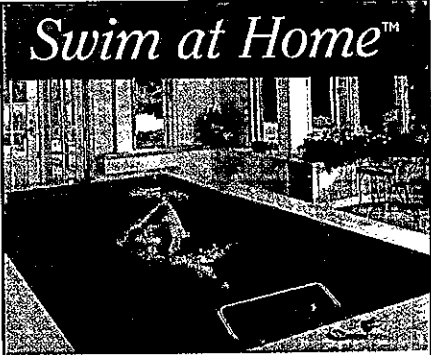

Introducing: The Treadmill for Swimmers!

Now you can swim for miles without moving an inch. Ideal for swimming, water aerobics, training, rehabilitation and fun.

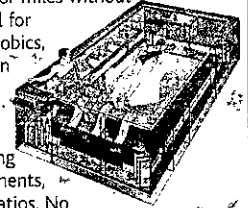

The 8' x 15' Endless Pool® fits into existing spaces such as basements, garages, decks and patios. No crowded pools, no heavy chlorine, no flip-turns.

Call for a FREE DVD or Video:
800.233.0741 ext. 4984

Or visit us at:
www.endlesspools.com/4984



200 E Dutton Mill Road
Aston, PA 19014