

# SAILING INSTRUCTIONS

## 1. RULES

- 1.1 Races will be governed by *The Racing Rules of Sailing* (RRS).
- 1.2 ADDENDUM Q will apply to CLUB 420, SNEAKBOX, and AM SUNFISH, and when in conflict amends these Sailing Instructions.
- 1.3 If there is a conflict between a rule in the Notice of Race and these Sailing Instructions, the Sailing Instructions will take precedence. This modifies RRS 63.7.
- 1.4 RRS 61 will be changed to require a boat to inform the race committee finish boat immediately after finishing of its intention to protest another boat and provide the sail number of the protested boat.

## 2. NOTICES TO COMPETITORS

Notices to competitors will be posted on the official notice board located in the vicinity of the registration desk at the regatta headquarters.

## 3. CHANGES IN SAILING INSTRUCTIONS

Any change in the sailing instructions will be posted at least two hours prior to the scheduled AM or PM Warning Signal.

## 4. SIGNALS MADE ASHORE

- 4.1 Signals made ashore will be displayed at the regatta headquarters.
- 4.2 When AP is displayed ashore, '1 minute' is replaced with 'not less than 30 minutes'. This modifies Race Signals.

## 5. ACCOUNTABILITY

- 5.1 Changes of registered skipper (person in charge) or sail number must be submitted in writing at the registration desk or a late entry boat prior to a boat's applicable warning signal. The skipper need not be the helmsman but must be on board while racing.
- 5.2 Any registered boat sailing in her starting area between her warning and starting signals will be considered a contestant for the purpose of determining Championship Series qualification.
- 5.3 The committee will endeavor to account for all entered boats. If a boat does not start or fails to finish, the skipper shall report personally or by radio directly to the Regatta Committee or Patrol Boat flying a patrol flag before leaving the course. The VHF Channel 68 may be used by competitors to report withdrawal from a race.

## 6. CLASS SIGNALS AND STARTING TIMES

See inside

## 7. THE COURSE

- 7.1 The course chart shows the approximate location of marks, the order in which marks are to be passed, and the side on which each mark is to be left.
- 7.2 The Class placard and number of course to be sailed by that Class will be displayed at its Preparatory Signal. This modifies RRS 27.1.
- 7.3 When courses 0 through 8 are signaled, the PORTABLE MARK COURSE ADDENDUM will apply.
- 7.4 The race committee signal boat may display the approximate compass bearing of the first leg.
- 7.5 Any special course will be posted on the Official Notice Board at least two hours prior to the scheduled Warning Signal.

## 8. MARKS

- 8.1 Permanent marks will be drums painted orange and white with identifying letters painted in black.
- 8.2 Temporary marks will be as noted in paragraphs 9.3, 11.2, 18, 26, 28, and AA on the Course Chart.

## 9. THE START

- 9.1 Races will be started using RRS 26.
- 9.2 When back-to-back races are scheduled for a class, AM or PM, the warning signal for the second race will be made as soon as practical. To alert boats that the second race will begin soon Flag Q will be displayed for at least 4 minutes over the class flags of the competing fleets. The sequence of the class flags, top to bottom, will indicate the order of start. Flying of the Class Flag under Flag Q does not designate the Warning Signal of classes.
- 9.3 The starting line will be between a staff displaying an orange flag on a Signal Boat at the starboard end and a large orange cone at the port end.
- 9.4 An orange ball attached to a Signal or Finish Boat is considered a part of the boat.
- 9.5 After starting and before finishing, a boat may not cross the start line.
- 9.6 A boat starting later than four minutes after her starting signal will be scored Did Not Start. This changes rule A4.1.

## 10. RECALLS

Recalls will be in accordance with RRS 29.1. The Race Committee may call sail numbers of the boats recorded OCS on VHF channel 68. This changes RRS 41. Failure to receive the transmission will not relieve a boat of the responsibility of starting properly, and is not grounds for redress. This changes RRS 62.1(a).

## 11. THE FINISH

- 11.1 For fixed mark courses the Race Committee will attempt to establish a windward finish and a patrol boat at the last turning mark may display a placard indicating the approximate bearing to the finish. Failure to do so will not be grounds for redress.
- 11.2 The finish line will be between a staff displaying an orange flag on a Finish Boat and a large orange cone, except as indicated in the PORTABLE MARK COURSE ADDENDUM.

## 12. TIME LIMIT

- 12.1 The time limit will be 2 hours. A boat finishing more than 20 minutes after the first boat of her class finishes will be scored "Did not finish". This changes RRS 35 & A4.1.
- 12.2 For morning races, no Warning Signal will be made after 11:30 AM. For afternoon races, no Warning Signal will be made after 3:30 PM.

## 13. PROTESTS

- 13.1 Protests shall be written on forms available at the regatta headquarters or line, finish, or signal boat, or online at [www.bbyra.org](http://www.bbyra.org). Protest forms may be lodged:
  - a) In person to the Protest Committee Chairman or secretary, or a BBYRA Flag Officer, or
  - b) Electronically at [www.bbyra.org](http://www.bbyra.org).All protests whether lodged in person or electronically must be submitted by 2000 hrs. on the day of the race in question, except on the last scheduled racing day when the protest time shall be 1 hour from the time the Signal boat docks.

13.2 Protest notices will be posted as soon as possible after the protest time limit on the official Protest Committee notice board at [www.bbrya.org](http://www.bbrya.org). Protests will be heard at Regatta Headquarters commencing at 0700 on the next scheduled race day, or at a location and time agreed upon by the protest committee and interested parties, except on the last race day when protests will be heard immediately following the races.

13.3 The time limit for any redress filings on the last scheduled racing day shall be the protest time limit. This modifies RRS 62.2

13.4 Boats may not protest other boats for infractions of Sailing Instructions 5.1, 15.1, 15.3, 21, and 24.

#### 14. PENALTY SYSTEM

14.1 RRS 44.1 is modified so that a boat that breaks a rule may either:

- a) take a two turn penalty or;
- b) take a scoring penalty as prescribed in RRS 44.3.

#### 15. SAFETY

15.1 All Club 420 and single handed competitors shall wear personal buoyancy at all times while afloat except for brief periods (e.g. changing clothes). This changes RRS 40, and the Part 4 preamble.

15.2 E Sloops shall deploy mainsail flotation at all times while racing.

15.3 Safety inspections will be conducted at the discretion of the Regatta Committee. Flag "L" and a class signal displayed at the finish line will indicate a mandatory inspection. Boats are required to respond by checking in with a safety patrol boat flying flag "L" and the class signal on station in the vicinity of the finish line. Boats must remain in the area until inspected and dismissed by the inspection team. While awaiting inspection, contact with other boats is prohibited. A boat that fails inspection or fails to comply with this sailing instruction will be protested.

#### 16. POSTPONEMENT SIGNAL ("AP", Answering Pennant)

This signal made before NOON does not refer to afternoon races. This modifies RRS Race Signals.

#### 17. COME WITHIN HAIL SIGNAL (Flag "L")

Flag "L", when displayed afloat to indicate "Come within Hail", is mandatory. Failure to respond will be grounds for disqualification. This modifies RRS Race Signals.

#### 18. MARK MISSING ("M")

A missing mark will be designated either by a black and yellow buoy or a buoy or vessel displaying Flag M. Sound signals while displaying "M" may be omitted. This modifies RRS Race Signals.

#### 19. ABANDONMENT SIGNALS ("N" & "N" over "A")

Flag "N" over "A" means, "All races including those not started are abandoned and will not be sailed." This signal made before 12:20 PM does not refer to afternoon races. This modifies RRS Race Signals.

#### 20. SHORTEN COURSE SIGNAL (Flag "S")

Flag "S" means "RRS 32.2 is in effect".

#### 21. RADIO COMMUNICATION

A boat shall neither make radio transmissions while racing nor receive radio communications not available to all competitors, or use a mobile telephone. Transmission from these devices is only allowed for emergencies. The Race committee will monitor VHF Channel 68 for emergency transmissions. The channel may also be used by competitors to report withdrawal from a race. The Race Committee will attempt to broadcast sail numbers of boats that are OCS for individual recalls on Channel 68

#### 22. Scoring

22.1 The Low Point scoring system of RRS Appendix A will apply. RRS A4.2 is replaced with RSS A.9, Race Scores in a Series Longer than a Regatta.

22.2 The number of scheduled races is as shown on the Class Schedule.

22.3 RRS A2 is changed such that:

- a) When 1 to 3 races have been completed in her class, a boat's series score will be the total of all her race scores.
- b) When 4 to 6 races have been completed for her class, a boat's score will be the total of her race scores excluding her worst score.
- c) When 7 to 8 races have been completed for her class, a boat's score will be the total of her race scores excluding her two worst scores.
- d) When 9 to 12 races have been completed for her class, a boat's score will be the total of her race scores excluding her three worst scores.
- e) When 13 to 15 races have been completed for her class, a boat's score will be the total of her race scores excluding her four worst scores.
- f) When 16 or more races have been completed for her class, a boat's score will be the total of her race scores excluding her five worst scores.

22.4 Qualification for the Season Championship will be as prescribed in the Regulations of the BBYRA.

#### 23. DISCLAIMER OF LIABILITY

Competitors participate in the regatta entirely at their own risk. See RRS 4, Decision to Race. The Organizing Authority will not accept any liability for material damage or personal injury or death sustained in conjunction with or prior to, during, or after the regatta.

#### 24. DISPOSAL OF TRASH

Boats observed purposefully discharging trash on the water will be protested in all races sailed on the day the infraction is observed.

#### PORTABLE MARK COURSE ADDENDUM

The following instructions are applicable ONLY to courses 0 - 8:

#### 25. THE COURSE

25.1 The diagrams show the courses, the approximate angles between legs, the order in which marks are to be passed, and the side on which the marks are to be left.

25.2 A gate may be employed on any windward-leeward course. When there is a gate, boats shall sail between the gate marks from the direction of the previous mark and round either gate mark. Use of a gate will be signaled by display of placard "G" following the course number.

25.3 A short leeward mark may be used and will be signaled by placard "S" following the course number.

#### 26. MARKS

Marks will be yellow tetrahedrons. New marks, as provided in instruction 27, **CHANGING THE NEXT LEG OF THE COURSE**, will be orange tetrahedrons. The Initial Mark (IM) will be a large yellow cone. The short leeward mark will be a yellow tetrahedron with a black band

**27. CHANGING THE NEXT LEG OF THE COURSE** - A change of course after the start will be in accordance with RRS 33. When in a subsequent change of course a new mark is replaced, it will be replaced with an original mark.

**28. THE FINISH** - The finishing line will be between a staff displaying an orange flag on a Finish Boat displaying the flag/flags designating the class/classes using this finish line and an orange ball to weather of the windward mark except Courses 7 and 8 that will finish between a Finish Boat and an orange ball in the vicinity of the leeward mark.

### USE OF AN "INITIAL MARK"

On portable courses, the BBYRA is using an INITIAL MARK (IM) located to windward of the starting area. Boats must leave this mark to port prior to assuming the posted course. The initial mark will be placed approximately 100-200 yards to the right of the first portable mark. See Diagrams.

### USE OF A "SHORT LEEWARD MARK" (SI 25.3)

If a SHORT LEEWARD MARK is used it will be a yellow tetrahedron with a black band placed to windward of Mark 3.

## PORTABLE MARK COURSES

Note particularly SI 7.3, 11.2, 25, 26, 27 & 28

## TYPICAL

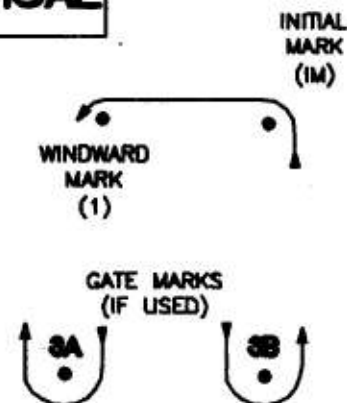

0

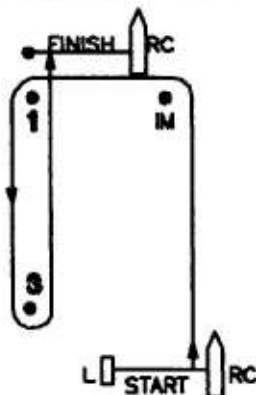

START-IM-1-3-FINISH

1

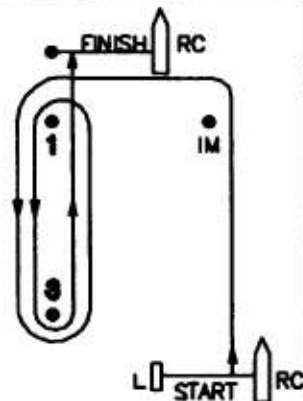

START-IM-1-3-1-3-FINISH

2

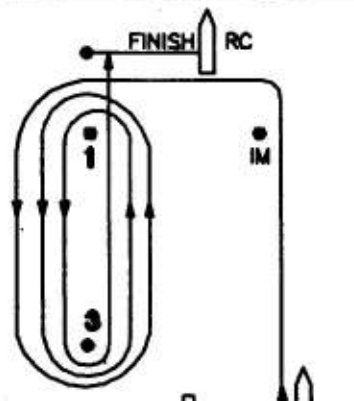

START-IM-1-3-1-3-1-3-FINISH

3

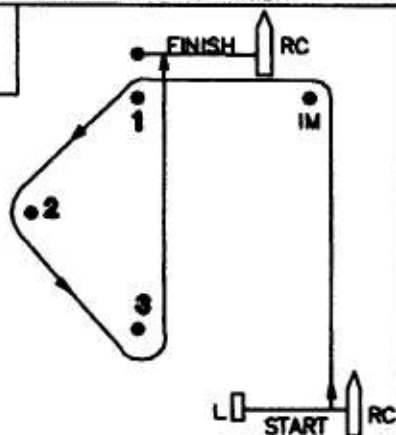

START-IM-1-2-3-FINISH

4

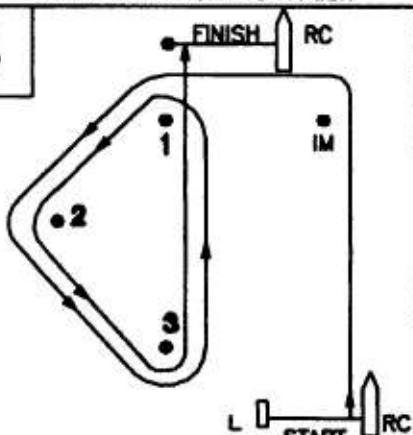

START-IM-1-2-3-1-2-3-FINISH

5

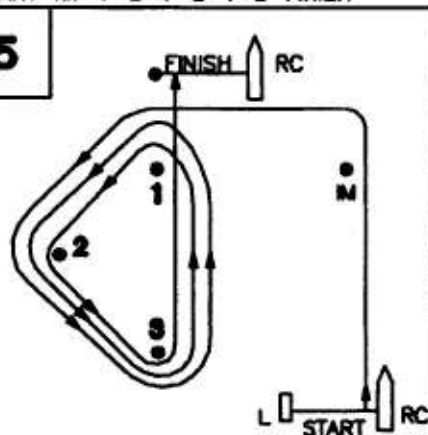

START-IM-1-2-3-1-2-3-1-2-3-FINISH

6

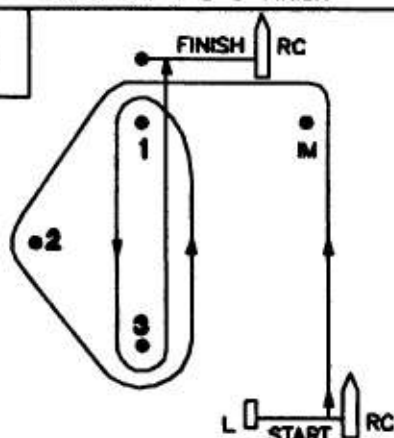

START-IM-1-2-3-1-3-FINISH

7

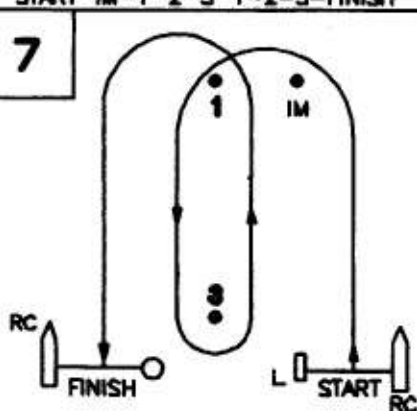

START-IM-1-3-1-FINISH

8

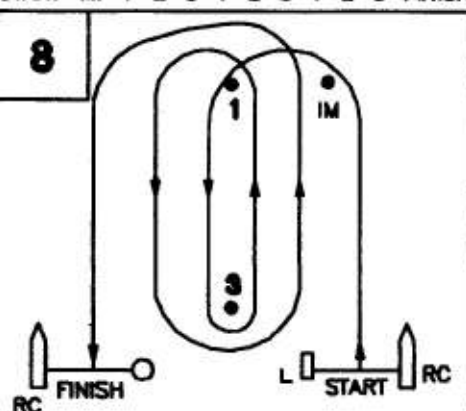

START-IM-1-3-1-3-1-FINISH

**ADDENDUM TO THE BBYRA 2008 SAILING INSTRUCTIONS FOR CLUB 420, AM SUNFISH, and SNEAKBOX FLEETS**

**1. RULES**

- 1.1 Races will be governed by *The Racing Rules of Sailing (RRS)*.
- 1.2 The BBYRA Sailing Instructions will apply except as modified herein.
- 1.3 RRS Appendix Q, Sound Signal Starting System will apply.
- 1.4 The Club 420 will be sailed in Collegiate Style Trim (no spinnaker and no trapeze).

**2. SCHEDULE**

- 2.1 On scheduled race days the first warning signal will be at 9:20 AM. Subsequent races will be started as soon as possible after the end of the previous race.
- 2.2 A maximum of Six (6) races per day will be scheduled for each fleet. No Warning Signal will be made after 11:30 AM.
- 2.3 The starting order will be 420, AM Sunfish, Sneakbox or as indicated by the race committee.

**3. THE COURSE**

- 3.1 The Upper Bay sailing area will be in the vicinity of the Lavallette YC and the Lower Bay sailing area will be in the vicinity of the Toms River YC. The SPYC race will be held on the Main course.
- 3.2 The course(s) will be Triangle, Olympic, Windward-Leeward, the "N" course (see diagram) or some combination of same.
- 3.3 Courses may be described orally, by placard or by chalkboard.

**4. MARKS**

The turning marks of the course will be yellow balls. The short leeward mark will be a yellow tetrahedron with a black band. The start and finish marks will be orange balls.

**5. THE START**

The start line will be between a staff displaying an orange flag on a Signal Boat at the starboard end and an orange ball at the port end.

**6. THE FINISH**

The finish line will be between a staff displaying an orange flag on a Finish Boat and an orange ball.

**7. CHANGING THE NEXT LEG OF THE COURSE**

When there is a course change marks may be relocated rather than replaced prior to the first boat rounding the preceding mark.

**8. SCORING FOR DAILY FLAGS AND TROPHIES**

- 8.1 On each scheduled race day, multiple races will be scored as a short series using the low point scoring system of RRS Appendix A. No scores will be excluded. This modifies RRS A2.
- 8.2 On each scheduled race day a boat's placement in the short series will be used for daily awards.

**9. CHAMPIONSHIP SERIES SCORING**

- 9.1 The low point scoring system of Appendix A will apply. RRS A9 Race Scores in a Series Longer than a Regatta, replaces RRS A4.2.
- 9.2 RRS A2 is modified so one (1) race will be excluded for every five (5) races completed.

“N” COURSE

